

KOBH

Altezza Seat-tube height H	CF	Lunghezza Top-tube length L c/c	Inclinazione Seat-tube angle		Punte forcella scatola Fork to bottom bracket S	Scatola/ forcellino posteriore Chain stay to bottom bracket center AR	Altezza terra Bottom bracket height F	Curva forcella Fork rake F	Angolo Sterzo Steering Angle Y	Misura Sterzo Steering Sizes A
			α	α1						
			gradi/degrees	mm						
420	450	500	73,40°	120	561	413	270	47	69,50°	110
450	480	520	73,40°	128.5	571	413	270	47	71,00°	120
485	515	540	73,00°	142	573	413	265	47	73,00°	135
510	540	555	73,00°	149	588	413	265	47	73,00°	150
520	550	560	73,00°	152	592.5	413	265	47	73,00°	155
530	560	570	73,00°	155	602	413	265	47	73,00°	165
540	570	580	73,00°	158	612	413	265	47	73,00°	180
550	580	585	72,50°	165	612	413	265	47	73,00°	200

DOGMA® • PARIS • FPQUATTRO • FP3

Altezza Seat-tube height H	CF	Lunghezza Top-tube length L c/c	Inclinazione Seat-tube angle		Punte forcella scatola Fork to bottom bracket S	Scatola/ forcellino posteriore Chain stay to bottom bracket center AR	Altezza terra Bottom bracket height T	Curva forcella Fork rake F	Angolo Sterzo Steering Angle Y	Misura Sterzo Steering Sizes A
			α	α1						
			gradi/degrees	mm						
420-Only	440	498	74,40°	113	563	406	270	43	69,15°	110
440s	460	503	74,40°	118	565	406	270	43	70,00°	115
465s	485	515	74,40°	124	575	406	270	43	70,50°	120
500	520	525	74,00°	138	575	406	265	43	71,40°	125
515	535	535	73,70°	145	577,5	406	265	43	72,00°	130
530	550	545	73,70°	149	583	406	265	43	72,50°	144
540	560	550	73,40°	154	583	406	265	43	72,80°	152
550	570	557	73,40°	157	590	408	265	43	72,80°	163
560	590	565	73,00°	163	592	408	265	43	73,20°	170
575	595	575	73,00°	168	596	408	265	43	73,70°	184
595	615	587	72,40°	180	605	408	270	43	73,40°	210
620-Only	640	620	72,00°	192	633	411	270	43	73,40°	240

PARIS • FPQUATTRO • FP3 EASYFIT

425	445	500	74,00°	117	565	406	265	43	70,00°	120
460	480	512	74,00°	127	570	406	265	43	71,00°	135
490	510	528	73,50°	139	575	406	265	43	72,00°	145
510	530	545	73,00°	149	588	406	265	43	72,00°	155

FP2

440	460	505	74,40°	118	565	406	270	43	70,20°	120
470	490	528	74,00°	129,5	579	406	265	43	71,00°	125
510	530	537	73,50°	145	580	406	265	43	71,70°	131
530	550	550	73,50°	152	583	406	265	43	72,70°	153
550	570	560	73,00°	161	589	408	265	43	72,80°	168
570	590	575	72,50°	171	598	410	270	43	73,00°	185
590	610	585	72,00°	182	597	410	270	43	73,00°	208



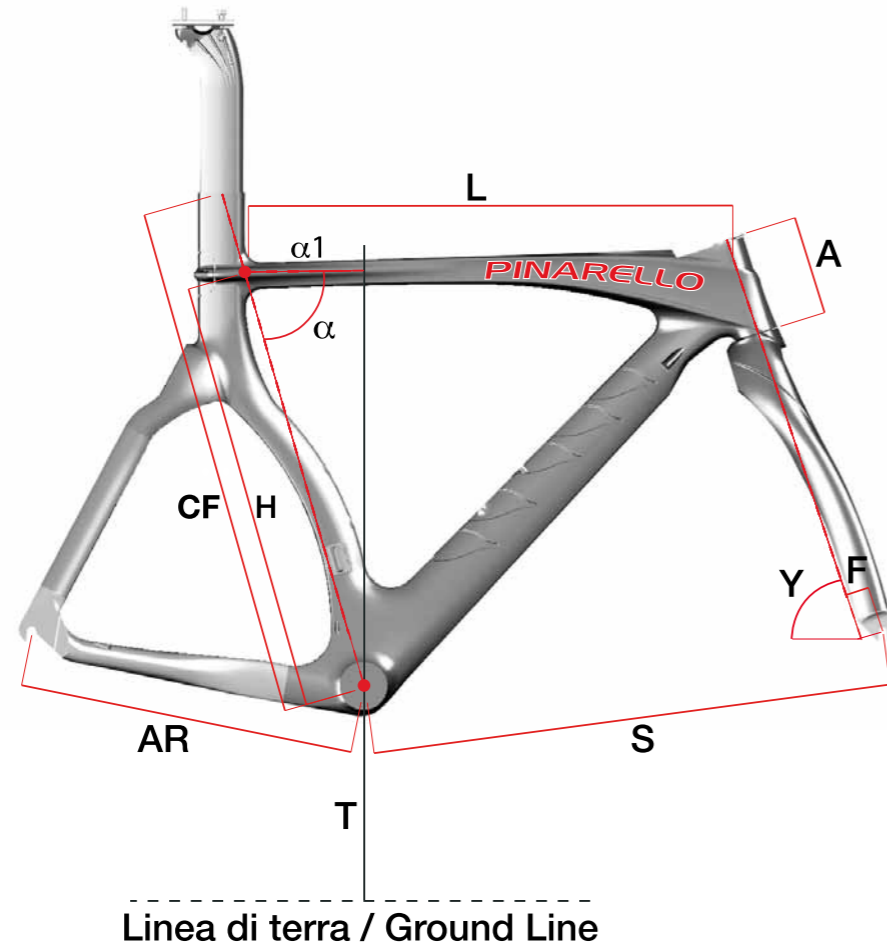

GRAAL

Altezza Seat-tube height H	CF	Lunghezza Top-tube length L c/c	Inclinazione Seat-tube angle		Punte forcella scatola Fork to bottom bracket S	Scatola/ forcellino posteriore Chain stay to bottom bracket center AR	Altezza terra Bottom bracket height T	Curva forcella Fork rake F	Angolo Sterzo Steering Angle Y	Misura Sterzo Steering Sizes A
			α	$\alpha 1$						
			gradi/degrees	mm						
450	510	500	75,50°	113	557	385	275	43	72,00°	75
490	540	515	75,50°	123	567	385	275	43	73,00°	90
510	560	530	75,50°	128	582	385	265	47	73,00°	100
530	580	545	75,50°	133	598	385	265	47	73,00°	115
550	600	560	75,50°	138	614	385	265	47	73,00°	130
575	625	575	75,50°	144	630	385	265	47	73,00°	155

FT3 • FT1

460	510	500	76,00°	90	557	385	275	43	73,00°	111
490	540	520	76,00°	100	578	385	275	43	73,00°	118
530	580	545	76,00°	115	602	385	275	43	73,00°	128
550	600	560	76,00°	135	619	385	275	43	73,00°	133
570	620	575	76,00°	155	635	385	275	43	73,00°	138

XTrack

460s	487	520	75°25'	117	552	375	285	38	74°50'	110
515	542	536	74°50'	137,5	564	375	285	38	74°50'	144
532	559	552	74°50'	142	579,5	375	285	38	74°50'	160
550	577	567	74°50'	147	594	375	285	38	74°50'	174
580	607	582	73°75'	162	600	375	285	38	74°50'	204

Pista

460s	495	520	75°25'	117	552	395	285	38	74°50'	110
515	550	536	74°50'	137,5	564	395	285	38	74°50'	144
532	567	552	74°50'	142	579,5	395	285	38	74°50'	160
550	585	567	74°50'	147	594	395	285	38	74°50'	174
580	615	582	73°75'	162	600	395	285	38	74°50'	204



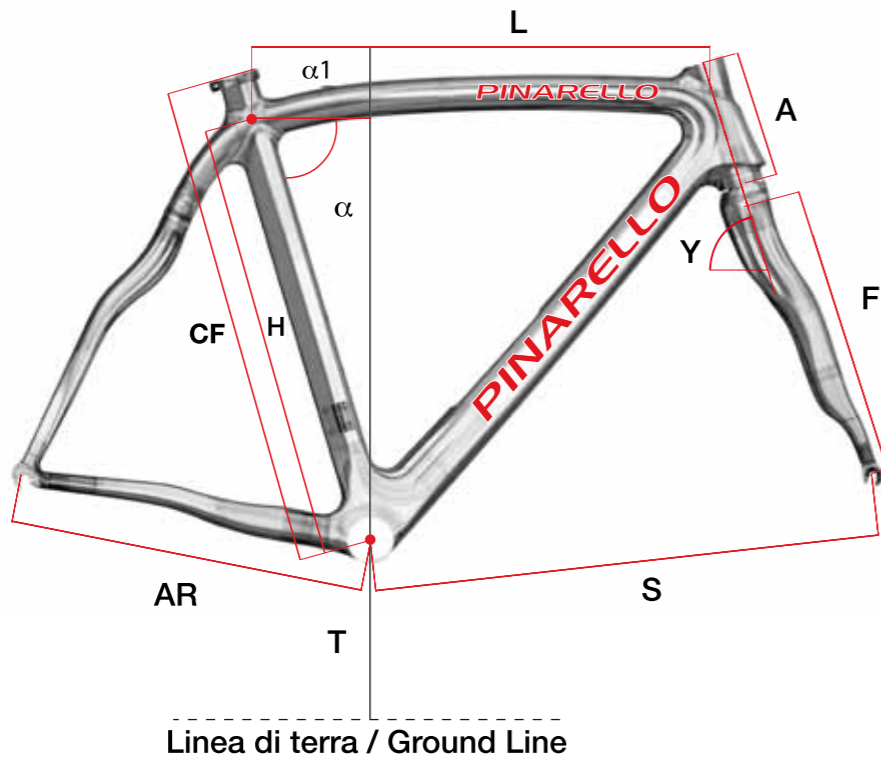

CX Cross

Altezza Seat-tube height H	CF	Lunghezza Top-tube length L c/c	Inclinazione Seat-tube angle		Punte forcella scatola Fork to bottom bracket S	Scatola/ forcellino posteriore Chain stay to bottom bracket center AR	Altezza terra Bottom bracket height T	Curva forcella Fork rake F	Angolo Sterzo Steering Angle Y	Misura Sterzo Steering Sizes A
			α gradi/degrees	$\alpha 1$ mm						
460s	495	512	75,00°	119	558	420	275	50	70,00°	108
480s	515	518	74,00°	132	587	420	275	50	70,00°	108
500s	535	530	74,00°	138	592	420	275	50	71,00°	125
520s	555	540	74,00°	143	603	420	275	50	71,00°	145
540s	575	555	74,00°	149	620	420	280	50	71,00°	170
560s	595	565	74,00°	154	622	420	280	50	72,00°	180

FP1

Altezza Seat-tube height H	CF	Lunghezza Top-tube length L c/c	Inclinazione Seat-tube angle		Punte forcella scatola Fork to bottom bracket S	Scatola/ forcellino posteriore Chain stay to bottom bracket center AR	Altezza terra Bottom bracket height T	Curva forcella Fork rake F	Angolo Sterzo Steering Angle Y	Misura Sterzo Steering Sizes A
			α gradi/degrees	$\alpha 1$ mm						
440s	475	510	74°50'	117,5	565	403	273	43	71,00°	110
460s	495	515	74°50'	123	571	403	270	43	71,00°	113
500	535	528	74°25'	136	57,3	406	265	43	72,25°	120
520	555	540	73°65'	147	582	406	265	43	72,00°	139
540	575	550	73°45'	154	583	408	265	43	72,80°	152
560	595	565	73°35'	161	592	408	265	43	73,45°	172
580	615	575	72°50'	174	596	409	268	43	73,15°	190
600	635	585	72°50'	181	604	409	273	43	73,15°	214
620	655	595	72°00'	191,5	610	410	273	43	72,90°	235

Lungavita

450	485	520	75,00°	117	580	404	270	43	71,00°	110
480	515	536	74,00°	132	580	404	270	43	72,50°	135
510	545	552	73,50°	145	588	404	270	43	73,00°	160
530	565	567	73,50°	150	600	404	270	43	73,00°	180
560	595	582	73,00°	164	612	404	270	43	73,00°	204

Treviso

450	470	510	73,30°	129	569	410	270	45	72,00°	110
500	520	524	73,30°	143	598	410	270	45	72,00°	125
540	560	555	73,30°	155	603	410	270	45	72,00°	145
580	600	580	73,00°	170	610	410	270	45	72,00°	155

FPZero - Kids

380	415	465	75,50°	95	526	350	250	45	72,50°	97
-----	-----	-----	--------	----	-----	-----	-----	----	--------	----





SVILUPPO METRICO ruote strada Rapporto Anteriore / Rapporto posteriore x 2,115

	11	12	13	14	15	16	17	18	19	20	21	22	23	24	25	26	27	28	29	30	31	32
22	4,230	3,878	3,579	3,324	3,102	2,908	2,737	2,585	2,449	2,327	2,216	2,115	2,023	1,939	1,861	1,790	1,723	1,662	1,604	1,551	1,501	1,454
24	4,615	4,230	3,905	3,626	3,384	3,173	2,986	2,820	2,672	2,538	2,417	2,307	2,207	2,115	2,030	1,952	1,880	1,813	1,750	1,692	1,637	1,586
26	4,999	4,583	4,230	3,928	3,666	3,437	3,235	3,055	2,894	2,750	2,619	2,500	2,391	2,291	2,200	2,115	2,037	1,964	1,896	1,833	1,774	1,718
28	5,384	4,935	4,555	4,230	3,948	3,701	3,484	3,290	3,117	2,961	2,820	2,692	2,575	2,468	2,369	2,278	2,193	2,115	2,042	1,974	1,910	1,851
30	5,768	5,288	4,881	4,532	4,230	3,966	3,732	3,525	3,339	3,173	3,021	2,884	2,759	2,644	2,538	2,440	2,350	2,266	2,188	2,115	2,047	1,983
32	6,153	5,640	5,206	4,834	4,512	4,230	3,981	3,760	3,562	3,384	3,223	3,076	2,943	2,820	2,707	2,603	2,507	2,417	2,334	2,256	2,183	2,115
34	6,537	5,993	5,532	5,136	4,794	4,494	4,230	3,995	3,785	3,596	3,424	3,269	3,127	2,996	2,876	2,766	2,663	2,568	2,480	2,397	2,320	2,247
36	6,922	6,345	5,857	5,439	5,076	4,759	4,479	4,230	4,007	3,807	3,626	3,461	3,310	3,173	3,046	2,928	2,820	2,719	2,626	2,538	2,456	2,379
38	7,306	6,698	6,182	5,741	5,358	5,023	4,728	4,465	4,230	4,019	3,827	3,653	3,494	3,349	3,215	3,091	2,977	2,870	2,771	2,679	2,593	2,512
39	7,499	6,874	6,345	5,892	5,499	5,155	4,852	4,583	4,341	4,124	3,928	3,749	3,586	3,437	3,299	3,173	3,055	2,946	2,844	2,750	2,661	2,578
40	7,691	7,050	6,508	6,043	5,640	5,288	4,976	4,700	4,453	4,230	4,029	3,845	3,678	3,525	3,384	3,254	3,133	3,021	2,917	2,820	2,729	2,644
41	7,883	7,226	6,670	6,194	5,781	5,420	5,101	4,818	4,564	4,336	4,129	3,942	3,770	3,613	3,469	3,335	3,212	3,097	2,990	2,891	2,797	2,710
42	8,075	7,403	6,833	6,345	5,922	5,552	5,225	4,935	4,675	4,442	4,230	4,038	3,862	3,701	3,553	3,417	3,290	3,173	3,063	2,961	2,865	2,776
43	8,268	7,579	6,996	6,496	6,063	5,684	5,350	5,053	4,787	4,547	4,331	4,134	3,954	3,789	3,638	3,498	3,368	3,248	3,136	3,032	2,934	2,842
44	8,460	7,755	7,158	6,647	6,204	5,816	5,474	5,170	4,898	4,653	4,431	4,230	4,046	3,878	3,722	3,579	3,447	3,324	3,209	3,102	3,002	2,908
45	8,652	7,931	7,321	6,798	6,345	5,948	5,599	5,288	5,009	4,759	4,532	4,326	4,138	3,966	3,807	3,661	3,525	3,399	3,282	3,173	3,070	2,974
46	8,845	8,108	7,484	6,949	6,486	6,081	5,723	5,405	5,121	4,865	4,633	4,422	4,230	4,054	3,892	3,742	3,603	3,475	3,355	3,243	3,138	3,040
47	9,037	8,284	7,647	7,100	6,627	6,213	5,847	5,523	5,232	4,970	4,734	4,518	4,322	4,142	3,976	3,823	3,682	3,550	3,428	3,314	3,207	3,106
48	9,229	8,460	7,809	7,251	6,768	6,345	5,972	5,640	5,343	5,076	4,834	4,615	4,414	4,230	4,061	3,905	3,760	3,626	3,501	3,384	3,275	3,173
49	9,421	8,636	7,972	7,403	6,909	6,477	6,096	5,758	5,454	5,182	4,935	4,711	4,506	4,318	4,145	3,986	3,838	3,701	3,574	3,455	3,343	3,239
50	9,614	8,813	8,135	7,554	7,050	6,609	6,221	5,875	5,566	5,288	5,036	4,807	4,598	4,406	4,230	4,067	3,917	3,777	3,647	3,525	3,411	3,305
51	9,806	8,989	8,297	7,705	7,191	6,742	6,345	5,993	5,677	5,393	5,136	4,903	4,690	4,494	4,315	4,149	3,995	3,852	3,719	3,596	3,480	3,371
52	9,998	9,165	8,460	7,856	7,332	6,874	6,469	6,110	5,788	5,499	5,237	4,999	4,782	4,583	4,399	4,230	4,073	3,928	3,792	3,666	3,548	3,437
53	10,190	9,341	8,623	8,007	7,473	7,006	6,594	6,228	5,900	5,605	5,338	5,095	4,874	4,671	4,484	4,311	4,152	4,003	3,865	3,737	3,616	3,503
54	10,383	9,518	8,785	8,158	7,614	7,138	6,718	6,345	6,011	5,711	5,439	5,191	4,966	4,759	4,568	4,393	4,230	4,079	3,938	3,807	3,684	3,569
55	10,575	9,694	8,948	8,309	7,755	7,270	6,843	6,463	6,122	5,816	5,539	5,288	5,058	4,847	4,653	4,474	4,308	4,154	4,011	3,878	3,752	3,635
56	10,767	9,870	9,111	8,460	7,896	7,403	6,967	6,580	6,234	5,922	5,640	5,384	5,150	4,935	4,738	4,555	4,387	4,230	4,084	3,948	3,821	3,701
57	10,960	10,046	9,273	8,611	8,037	7,535	7,091	6,698	6,345	6,028	5,741	5,480	5,242	5,023	4,822	4,637	4,465	4,306	4,157	4,019	3,889	3,767
58	11,152	10,223	9,436	8,762	8,178	7,667	7,216	6,815	6,456	6,134	5,841	5,576	5,333	5,111	4,907	4,718	4,543	4,381	4,230	4,089	3,957	3,833
59	11,344	10,399	9,599	8,913	8,319	7,799	7,340	6,933	6,568	6,239	5,942	5,672	5,425	5,199	4,991	4,799	4,622	4,457	4,303	4,160	4,025	3,900
60	11,536	10,575	9,762	9,064	8,460	7,931	7,465	7,050	6,679	6,345	6,043	5,768	5,517	5,288	5,076	4,881	4,700	4,532	4,376	4,230	4,094	3,966

